

Алматы (7273)495-231
Ангарск (3955)60-70-56
Архангельск (8182)63-90-72
Астрахань (8512)99-46-04
Барнаул (3852)73-04-60
Белгород (4722)40-23-64
Благовещенск (4162)22-76-07
Брянск (4832)59-03-52
Владивосток (423)249-28-31
Владикавказ (8672)28-90-48
Владимир (4922) 49-43-18
Волгоград (844)278-03-48
Вологда (8173)26-41-59
Воронеж (473)204-51-73
Екатеринбург (343)384-55-89

Ижевск (3412)26-03-58
Иваново (4932)77-34-06
Иркутск (395)279-98-46
Казань (843)208-01-48
Калининград (4012)72-03-81
Калуга (4842)92-23-67
Кемерово (3842)65-04-62
Киров (8332)68-02-04
Коломна (4966)23-41-49
Кострома (4942)77-07-48
Краснодар (861)203-40-90
Красноярск (391)204-63-61
Курск (4712)77-13-04
Курган (3522)50-90-47
Липецк (4742)52-20-81

Магнитогорск (3519)55-03-13
Москва (495)268-04-70
Мурманск (8152)59-64-93
Набережные Челны (8552)20-53-41
Нижний Новгород (831)429-08-12
Новокузнецк (3843)20-46-81
Новыйск (3496)41-32-12
Новосибирск (383)227-86-73
Ноябрьск (3496)41-32-12
Омск (3812)21-46-40
Орел (4862)44-53-42
Оренбург (3532)37-69-04
Пенза (8412)22-31-16
Петрозаводск (8142)55-98-37
Псков (8112)59-10-37

Пермь (342)205-81-47
Ростов-на-Дону (863)308-18-15
Рязань (4912)46-61-64
Самара (846)206-03-16
Саранск (8342)22-96-24
Санкт-Петербург (812)309-46-40
Саратов (845)249-38-78
Севастополь (8692)22-31-93
Симферополь (3652)67-13-56
Смоленск (4812)29-41-54
Сочи (862)225-72-31
Ставрополь (8652)20-65-13
Сыктывкар (8212)25-95-17
Сургут (3482)77-98-95
Тамбов (4752)50-40-97

Тверь (4822)63-31-35
Тольятти (8482)63-91-07
Томск (3822)96-41-53
Тула (4872)33-79-97
Тюмень (3452)66-21-18
Улан-Уда (3012)59-97-51
Ульяновск (8422)24-23-59
Уфа (347)229-48-12
Хабаровск (4212)92-98-04
Челябинск (351)202-03-61
Череповец (8202)49-02-64
Чита (3022)36-34-83
Якутск (4112)23-90-97
Ярославль (4852)69-52-93

Киргизия (996)312-96-26-47

Россия (495)268-04-70

Казахстан (772)734-952-31

<https://silc.nt-rt.ru> || scj@nt-rt.ru

Профессиональные гладильные столы с прямоугольной столешницей S/ARM, S/ARM-C, S/ARM-V, S/ARM-VC



Rectangular ironing table with electric heated and vacuum board - table top dimensions cm. 135x70. Provided with built-in vacuum group.

ACCESSORI - ACCESSORIES - ACCESSOIRES

- Gruppo ferrovapore – Steam iron group – Groupe fer à vapeur
- Ferro da stiro - Steam iron - Fer à repasser
- Braccio con forme stiramaniche e cuscino - Arm with sleeve and pillow forms - Bras avec formes jeannette et coussin
- Dispositivi di smacchiatura a caldo e freddo - Hot and cold spotting devices - Dispositifs de détachage à froid et chaud
- Gruppo supporto ferro con illuminazione - Iron support group with lighting - Groupe support de fer avec illumination

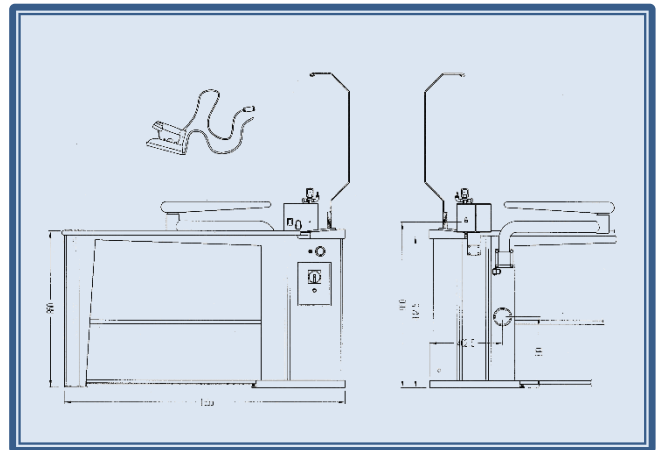
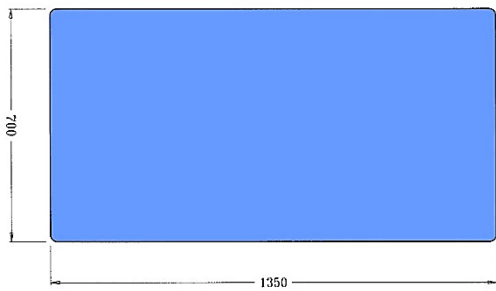

DATI TECNICI - TECHNICAL DATA - DONNÉES TECHNIQUES

Voltaggio - Voltage - Voltage	230/50/1
Potenza - Power - Puissance	2,2 kW
Resistenze piano – Board elements – Résistances plateau	1,8 kW
Aspiratore - vacuum - Aspirateur	0,372 kW
Peso netto - Net weight - Poids net	100 kg

S/ARM-C





Tavolo da stiro rettangolare con piano riscaldato elettrico ed aspirante - dimensioni piano cm. 135x70. Da collegare a fonte esterna di aspirazione. Valvola pneumatica di aspirazione inclusa.



Rectangular ironing table with electric heated and vacuum board - table top dimensions cm. 135x70. To be connected to central vacuum source. Pneumatic vacuum valve included.



Table a repasser rectangulaire avec plateau aspirante et réchauffée électrique - dimensions plateau cm. 135x70. A brancher à aspiration centrale. Valve d'aspiration pneumatique compris.

ACCESSORI - ACCESSORIES - ACCESSOIRES

- Gruppo ferrovapore – Steam iron group – Groupe fer à vapeur
- Ferro da stiro - Steam iron - Fer à repasser
- Braccio con forme stiramaniche e cuscino - Arm with sleeve and pillow forms - Bras avec formes jeannette et coussin
- Dispositivi di smacchiatura a caldo e freddo - Hot and cold spotting devices - Dispositifs de détachage à froid et chaud
- Gruppo supporto ferro con illuminazione - Iron support group with lighting - Groupe support de fer avec illumination

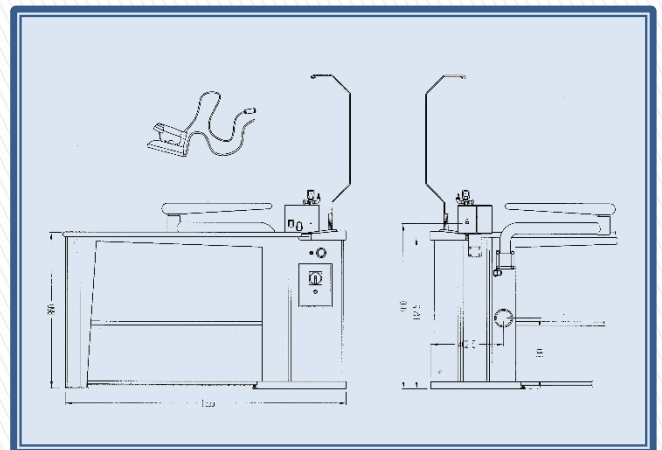
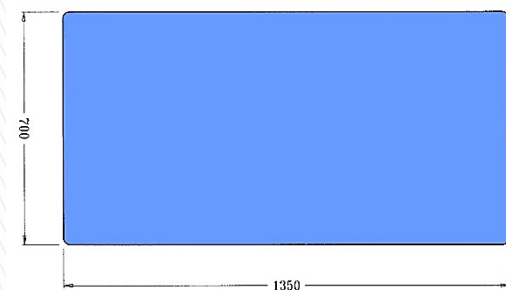

DATI TECNICI - TECHNICAL DATA - DONNÉES TECHNIQUES

Voltaggio - Voltage - Voltage	230/50/1
Potenza - Power - Puissance	1,8 kW
Resistenze piano – Board elements – Résistances plateau	1,8 kW
Peso netto - Net weight - Poids net	100 kg

S/ARM-V





Tavolo da stiro rettangolare con piano riscaldato a vapore ed aspirante - dimensioni piano cm. 135x70. Completo di aspiratore incorporato. Da collegare a fonte esterna di vapore.



Rectangular ironing table with steam heated and vacuum board - table top dimensions cm. 135x70. Provided with built-in vacuum group. To be connected to central steam.



Table a repasser rectangulaire avec plateau aspirante et réchauffée à vapeur - dimensions plateau cm. 135x70. Avec aspirateur incorporé. A brancher vapeur centrale.

ACCESSORI - ACCESSORIES - ACCESSOIRES

- Gruppo ferrovapore – Steam iron group – Groupe fer à vapeur
- Ferro da stiro - Steam iron - Fer à repasser
- Braccio con forme stiramaniche e cuscino - Arm with sleeve and pillow forms - Bras avec formes jeannette et coussin
- Gruppo supporto ferro con illuminazione - Iron support group with lighting - Groupe support de fer avec illumination

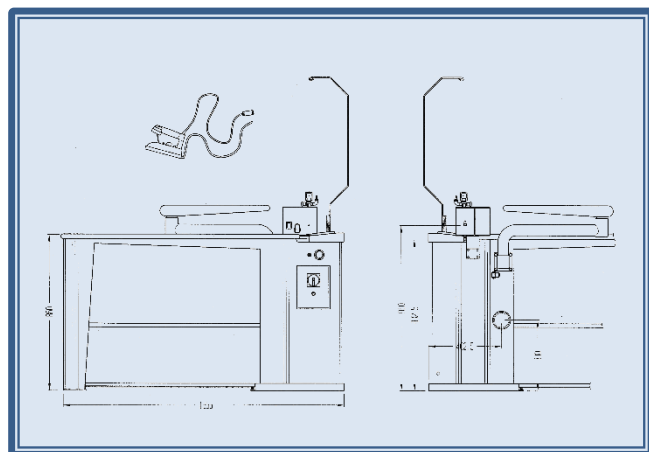
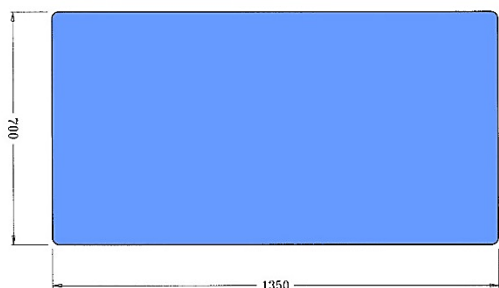

DATI TECNICI - TECHNICAL DATA - DONNESS TECHNIQUES

Voltaggio - Voltage - Voltage	230/50/1
Potenza - Power - Puissance	0,4 kW
Aspiratore - vacuum - Aspirateur	0,372 kW
Consumo vapore – Steam consumption – Consommation vapeur	10 kg/h (5 bar)
Peso netto - Net weight - Poids net	100 kg

S/ARM-VC



Rectangular ironing table with steam heated and vacuum board - table top dimensions cm. 135x70. To be connected to central steam and vacuum sources. Pneumatic vacuum valve included.

ACCESSORI - ACCESSORIES - ACCESSOIRES

- Gruppo ferrovapore – Steam iron group – Groupe fer à vapeur
- Ferro da stiro - Steam iron - Fer à repasser
- Braccio con forme stiramaniche e cuscino - Arm with sleeve and pillow forms - Bras avec formes jeannette et coussin
- Gruppo supporto ferro con illuminazione - Iron support group with lighting - Groupe support de fer avec illumination

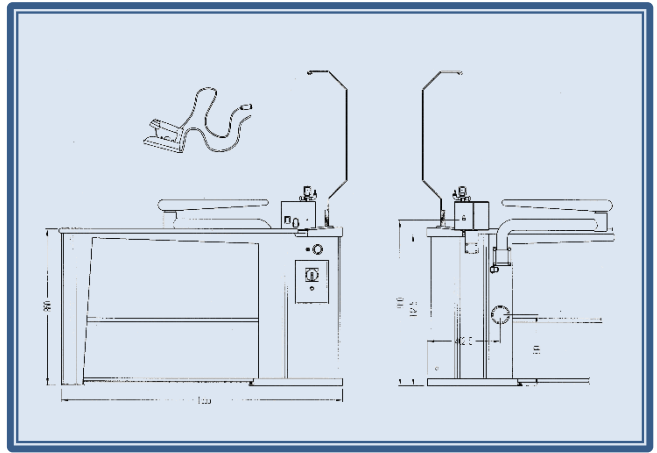
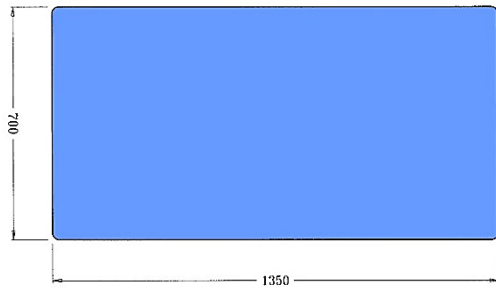

DATI TECNICI - TECHNICAL DATA - DONNESS TECHNIQUES

Voltaggio - Voltage - Voltage	230/50/1
Potenza - Power - Puissance	0,1 kW
Consumo vapore – Steam consumption – Consommation vapeur	10 kg/h (5 bar)
Peso netto - Net weight - Poids net	100 kg

Алматы (7273)495-231
 Ангарск (3955)60-70-56
 Архангельск (8162)63-90-72
 Астрахань (8512)99-46-04
 Барнаул (3852)73-04-60
 Белгород (4722)40-23-64
 Благовещенск (4162)22-76-07
 Брянск (4832)59-03-52
 Владивосток (423)249-28-31
 Владикавказ (8672)28-90-48
 Владимир (4922) 49-43-18
 Волгоград (844)279-03-48
 Вологда (8172)26-41-59
 Воронеж (473)204-51-73
 Екатеринбург (343)384-55-89

Ижевск (3412)26-03-58
 Иваново (4932)77-34-06
 Иркутск (395)279-98-46
 Казань (843)206-01-48
 Калининград (4012)72-03-81
 Калуга (4842)92-23-67
 Кемерово (3842)65-04-62
 Киров (8332)68-02-04
 Коломна (4966)23-41-49
 Кострома (4942)77-07-48
 Краснодар (861)203-40-90
 Красноярск (391)204-63-61
 Курск (4712)77-13-04
 Курган (3522)50-90-47
 Липецк (4742)52-20-81

Магнитогорск (3519)55-03-13
 Москва (495)268-04-70
 Мурманск (8152)59-64-93
 Набережные Челны (8552)20-53-41
 Нижний Новгород (831)429-08-12
 Новокузнецк (3843)20-46-81
 Ноябрьск (3496)41-32-12
 Новосибирск (383)227-86-73
 Ноябрьск (3496)41-32-12
 Омск (3812)21-46-40
 Орел (4862)44-53-42
 Оренбург (3532)37-68-04
 Пенза (8412)22-31-16
 Петрозаводск (8142)55-98-37
 Псков (8112)59-10-37

Пермь (342)205-81-47
 Ростов-на-Дону (863)308-18-15
 Рязань (4912)46-61-64
 Самара (846)206-03-16
 Саранск (8342)22-96-24
 Санкт-Петербург (812)309-46-40
 Саратов (845)249-38-78
 Севастополь (8692)22-31-93
 Симферополь (3652)67-13-56
 Смоленск (4812)29-41-54
 Сочи (862)226-72-31
 Ставрополь (8652)20-65-13
 Стыктыкар (8212)25-95-17
 Сургут (3462)77-98-35
 Тамбов (4752)50-40-97

Тверь (4822)63-31-35
 Тольятти (8482)63-91-07
 Томск (3822)98-41-53
 Тула (4872)33-79-87
 Тюмень (3452)66-21-18
 Улан-Удэ (3012)59-97-51
 Ульяновск (8422)24-23-59
 Уфа (347)229-48-12
 Хабаровск (4212)92-98-04
 Чебоксары (8352)28-53-07
 Челябинск (351)202-03-61
 Череповец (8202)49-02-64
 Чита (3022)38-34-83
 Якутск (4112)23-90-97
 Ярославль (4852)69-52-93

Киргизия (996)312-96-26-47

Россия (495)268-04-70

Казахстан (772)734-952-31